

WILSON RUHR

DEADWEIGHT GROUP
1850 – 2400 dwt

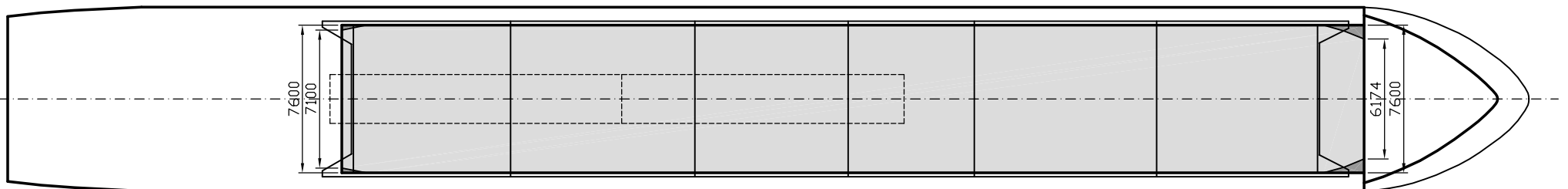

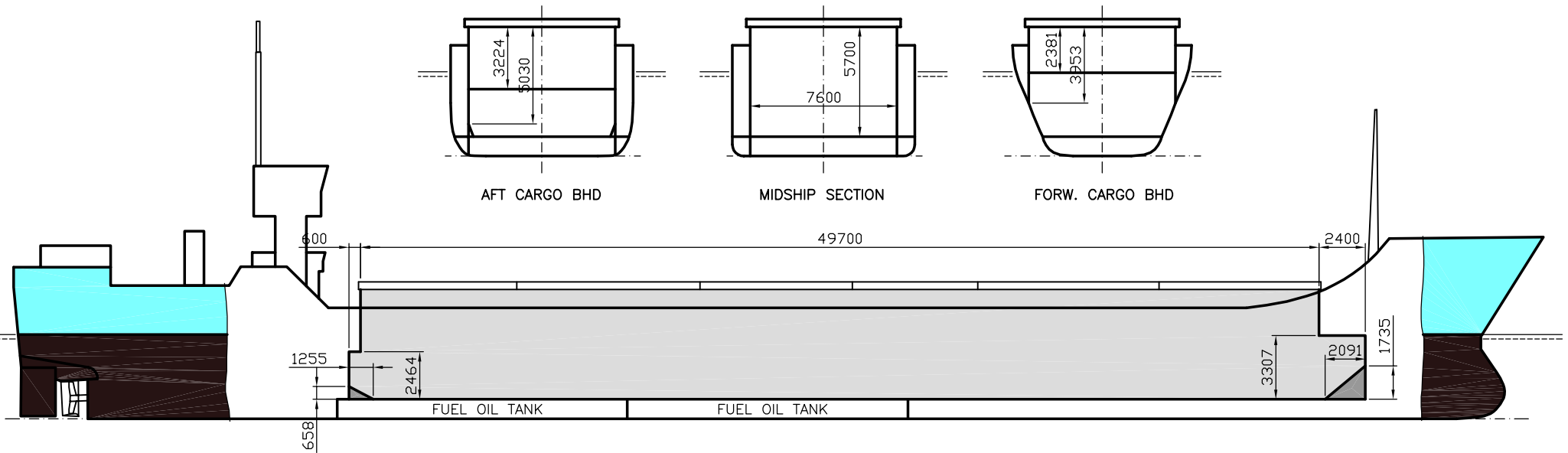

WILSON RUHR

Ex. Pilsen
 DWT GROUP 1850-2400
 IMO NO 9145542
 CALL SIGN 8PTA
 BUILD 1997
 FLAG Barbados

If not otherwise specified :
 Dist/Dim in meters
 Weights in m.tons

All details given in good faith without guarantee

Builders CSPL a.s. Chvaletice
Classification GL / +100 A5 M "E" "G" + MC E AUT
Length oa 78.89
Breadth mld 9.46
Depth mld 5.75
Draft summer 4.35
Deadweight summer draft 1857
Draft winter 4.35
Deadweight winter draft 1826
Gross tonnage 1169
Net tonnage 635
Immersion(load draft) TPC 7.14
Mean draft of ship in heavy ballast 3.05
Distance from forward end of No.1 Hatch to aft end of last hatch 49.10
Hatch type Kvaerner Multifold, Crocodile
Container (TEU) capacity Hold / Deck 46 / 24

Hatch details:

- a : Distance from waterline fully ballasted to top of hatch coamings
 b : Distance from waterline fully loaded to top of hatch coamings
 c : Distance from tank top to top of hatch coamings
 d : Max permissible loading on hatch covers
 e : Distance from ship's rail to inside hatch coamings
 f : Height of hatch coamings
 g : Hatch opening
 h : No. of Loadingholes on hatchcovers X diameter in mm

Remarks :

7 bulkhead positions are possible, bulkheads can be shifted by hatch cover.
 Figures given for ME tank capacity and consumption includes figures for AUX.

Max permissible load on deck, mt/sqm 1.44
Max permissible load on tanktop, mt/sqm 14.00
Max air draft - 1 19.50
Max air draft - 2 8.50
Distance from keel to top antenna -1 22.50
Distance from keel to top antenna -2 11.00
Water ballast capacity 828.45
Fuel main engine - capa.(cbm) 87.94
Fuel aux engine - capa.(cbm) -
Speed service, knots 9.00
Cargo gear No
Bow thruster Yes
Boxed No
Double skin Yes
Open hatch No
Rhine fitted Yes
Ammonium Nitrate fitted Yes
FeSi fitted Yes

Htch#	Bale							Grain				Hold#	cbm	cbft	Hold dimensions	Compartm :		Communication :		Equipment
	a	b	c	d	e	f	g	h	cbm	cbft	#					cbm	Type	No		
1	3.64	2.34	5.70	1.44	0.65	0.95	49.10 x 7.60	0	1	2072	73 173	2090	73 808	48.00 x 7.60 x 5.70			Telex 1	431 421 810	Inmarsat	
																	Telex 2	431 421 811	Inmarsat	
																	Tlph 1	+47 417 94168	Gsm	
																	Tlph 2	+47 417 94165	Gsm	
																	Fax	+47 474 10792	Gsm	
																	Email	w-ruhr@gtw.dualog.com		